



Leak Detecting Instruments

Leak De

PHOENIX Helium Leak Detectors

Contents

Leak Detecting Instruments

General

Applications for Leak Detecting Instruments	3
Leak Detection – Leak Testing	4
Leak Detection Methods.....	5
Operating Principles of the Helium Leak Detectors.....	7

Products

Fourth PHOENIX Generation.....	9
PHOENIX Quadro	10
PHOENIX Vario	12
Mobile Leak Detection Systems PHOENIX 4 Cart.....	15
Accessories for PHOENIX Quadro and PHOENIX Vario.....	19

Accessories

CART for PHOENIX Quadro and PHOENIX Vario	21
RC 310 C / RC 310 WL.....	22
Helium Sample Probes (Sniffers)	24
Calibrated Leaks for Vacuum and Sniffer Applications.....	26
Screw-in Calibrated Leaks.....	28

Miscellaneous

Connection Flanges.....	30
Connection Components.....	30

General

Applications for Leak Detecting Instruments

Test Instruments / Leak Detectors	PHOENIX Quadro	PHOENIX Quadro Dry Plus	PHOENIX Vario	PHOENIX Vario (oil sealed)
Applications				
Semiconductor production	■	■	■	
Vacuum coating	■	■		■
Research and development	■	■	■	■
Chemistry/pharmaceutical	■	■	■	■
Metallurgy/furnaces	■		■	■
Metallurgy/furnaces	■			■
Automotive industry	■			■
Laser engineering	■	■		
Particle accelerators		■	■	
Analytical engineering	■	■	■	■
Systems with cryopumps	■	■	■	■
Cooling and air conditioning		■	■	
Electrical engineering	■	■	■	■
Mechanical engineering	■			■
Power plants	■			■
Systems engineering	■	■	■	■
UHV applications	■	■	■	■

Leak Detection – Leak Testing

Whether a component or a system is leak-tight depends on the application it is to be used in and the leak rate that is acceptable. Absolutely leak-tight components and systems do not exist. A component is considered technically leak-tight if its leak rate remains below a value defined for this particular component. In order to provide a quantitative measure, the term “leak rate” with the symbol “ q_L ” was introduced. In vacuum technology mbar x l/s is used as the unit for leak rates.

A leak rate of 1 mbar x l/s exists in a closed vessel having a volume of 1 liter when the pressure increases by 1 mbar within one second, or in case of an overpressure it decreases by 1 mbar within one second.

$$q_L = \frac{V \times \Delta p}{\Delta t} \quad (\text{mbar x l/s})$$

The wide range of leak rates from several 100 mbar x l/s to below 10^{-11} mbar x l/s as they occur in practice necessitates the use of different leak

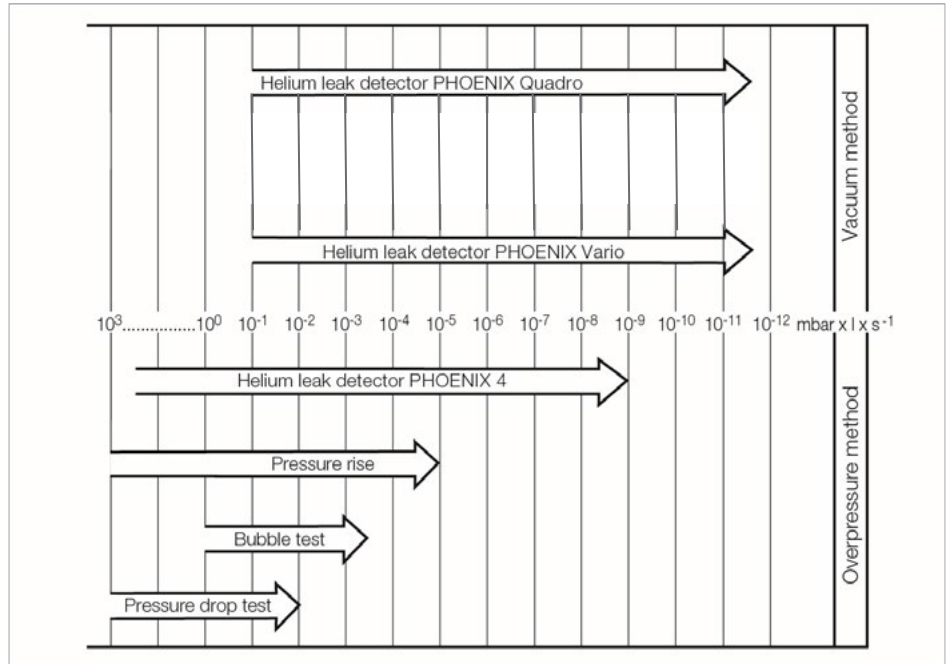

Overview of the leak rate detection ranges

detection principles and hence leak detectors (see figure).

Besides the determination of the total leak tightness, it is usually important to locate the leak, quickly and precisely, in order to seal it. Instruments for local

leak detection are called leak detectors. The leak detectors presented in this product section can be used for the localization of leaks, and in addition some are suitable for determining the total leak rate of test objects.

Leak Rate

	Pa x m ³ /s	atm x cm ³ /s ^{*)} mbar x l/s ^{*)}	atm x cm ³ /s ^{*)} cm ³ /s ^{*)}
Pa x cm ³ /s	1	10	9.87
1 mbar x l/s (He)	0.1	1	0.99
1 atm x cm ³ /s ^{*)} = cm ³ (STP) /s	0.101	1.01	1
1 Torr x l/s ^{*)}	0.133	1.33	1.33
1 kg/h air	23.4	234	234
1 g/a C ₂ H ₂ F ₄ (R 134a)	6,41 x 10 ⁻⁷	7,58 x 10 ⁻⁶	6,3 x 10 ⁻⁶

Leak Rate

	atm x cm ³ /s ^{*)} Torr x l/s ^{*)}	kg/h Air	g/a C ₂ H ₂ F ₄ (R 134a)
Pa x cm ³ /s	7.5	4.28 x 10 ⁻²	2.28 x 10 ⁶
1 mbar x l/s (He)	0.75	4.3 x 10 ⁻³	2.28 x 10 ⁵
1 atm x cm ³ /s ^{*)} = cm ³ (STP) /s	0.76	4.3 x 10 ⁻³	2.3 x 10 ⁵
1 Torr x l/s ^{*)}	1	5.7 x 10 ⁻³	3.0 x 10 ⁵
1 kg/h air	175	1	–
1 g/a C ₂ H ₂ F ₄ (R 134a)	4,8 x 10 ⁻⁶	–	1

^{*)} According to international system of units only Pa x m³/s is permissible

Leak Detection Methods

There are two main groups of leak detection methods; for both there are special instruments available:

Vacuum Methods

The equipment to be tested is evacuated. The pressure ratio between inside and outside is 0:1.

Overpressure Methods

The equipment to be tested is pressurized with a search gas or a search gas mixture.

The pressure ratio between inside and outside is over 1:1.

Between the two methods there exist many variations depending on the particular application.

General Notes

1. The lowest leak rates can only be measured by employing the vacuum method, whereby the following applies: The lower the leak rate, the higher the requirements are concerning cleanliness and ultimate vacuum.
2. If possible the test objects should be tested under the same conditions that will be used in their final application, i.e. parts for vacuum operation should be tested according to the vacuum method and parts for overpressure operation should be tested using the overpressure method.

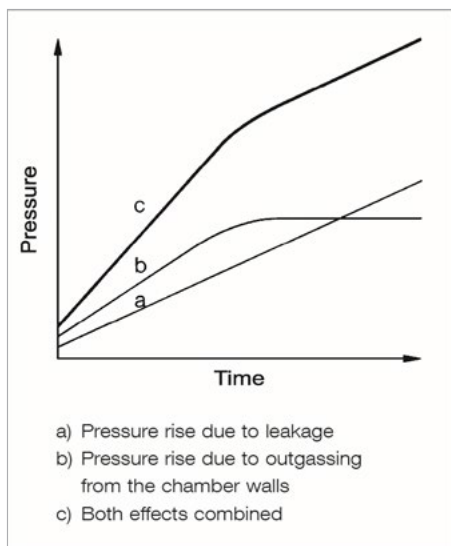

Pressure rise in a vacuum chamber after switching off the pump; double log. plot

Leak Testing Based on Vacuum Methods

(Vacuum inside the test object.)

Pressure Rise Method

With this method it is only possible to determine the total leak rate. The test object is evacuated with a vacuum pump or a vacuum pump system. A valve is used to isolate the test object from the vacuum pump. The pressure will then rise as a function of time. Curve (a) shows the theoretical pressure rise if there is only a leak. Curve (b) shows the pressure rise due to outgassing from the surfaces of the test object. This pressure rise tends to tail off in the direction of a saturation level. If in such a case the time allowed for monitoring the pressure rise is too short, a leak will be indicated which in reality does not exist. If one waits long enough for the pressure to rise, i.e. after the bend of curve (b) the outgassing process can then be disregarded, so that the leak rate can be determined from the known volume of the test object and the measured pressure rise over a fixed rise time (see equation on page before). Curve (c) shows the pressure rise as it occurs in practice, where out-gassing and leak rate add. The detectable leak rate depends on the volume of the test object, the obtained ultimate pressure and the outgassing from the test object. In connection with very large test objects this method is time consuming if extremely low leak rates are to be determined in the fine and rough vacuum range.

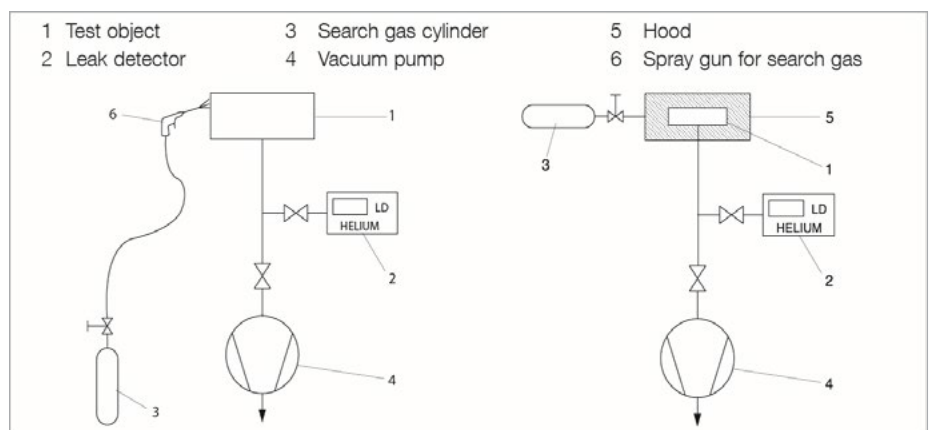

Local leak detection – Evacuated test object (left) and Integral method – Evacuated test object (right)

Local Leak Detection

The test object is evacuated by a vacuum pump (auxiliary pump) until the pressure is low enough for the leak detector to operate. When using a helium leak detector, its own pump system will take care of further evacuation. Suspicious spots on the test object will then be sprayed with a fine jet of search gas. Search gas entering through leaks into the test object is pumped out by the vacuum pump and it is converted by the leak detector into an electrical signal which is then displayed. This permits rapid detection and determination of the size of even the smallest leaks.

Integral Method

Determination of the total leak rate of a test object. The testing arrangement is the same as for local leak detection, but in this case the test object is not sprayed with search gas on selected areas, but it is surrounded by a hood or a chamber which is filled with the search gas. Thus the entire outer surface of the test object comes into contact with the search gas. If the search gas enters the test object, the total leak rate is indicated independently of the number of existing leaks. With helium leak detectors it is possible to determine the helium content of the air. This is utilized in the detection of gross leaks.

Leak Testing Based on Overpressure Methods

(Overpressure within the test object.)

Pressure Drop Method

The test object is filled with a gas (for example air or nitrogen) until the testing pressure is reached. Precision vacuum gauges are used to detect a possible pressure drop during the testing period. This method is simple to implement, it is suitable for the determination of gross leaks and can be improved upon by using differential pressure gauges. By applying soap solutions or similar, leaks can be located.

Local Leak Detection with Leak Detectors – Sniffing

The test object is filled with the search gas or the search gas/air mixture to which the leak detector is sensitive. The leak detector is equipped with a sniffer probe, whereby there is a low pressure at the probe tip. If the sniffer tip passes suspicious points on the test object the search gas coming out of the leak is sucked in and transferred to the detection system of the leak detector. After conversion into electrical signals these are displayed optically and acoustically by the leak detector.

Integral Method – Hood Test

To determine the total leak rate of a test object subjected to a search gas overpressure, the test object is surrounded by a hood of a known volume. The search gas which escapes through the leaks collects in the hood.

After a fixed accumulation period a sniffer probe is used to measure the concentration of the search gas which has collected in the hood.

Before this the leak detector should be calibrated by a reference measurement using a known search gas concentration.

The leak rate can then be determined by the equation for q_L where V is the volume of the hood, Δp is the partial pressure difference of the search gas (concentration change) and t is the accumulation period.

Uncertainties in the determination of the volume, leaks in the hood and a wrong accumulation period make precise leak rate measurements based on this method very questionable.

Integral Method – Vacuum Hood Test

This test is a variation of the hood test described above, which has considerable advantages. A vacuum chamber which is evacuated by an auxiliary pump and which is connected to a leak detector is used as the hood. The search gas escaping through the leaks is converted by the detection system of the leak detector into electrical signals which are immediately displayed. After calibration of the leak detector with a calibrated leak it is possible to quantitatively determine the total leak rate.

This method permits the detection of very small leaks and is especially suited for automatic industrial leak detection.

Integral Method – Bombing-Test

This method is used for testing hermetically sealed components such as transistors, IC-packages or dry reed relays. It is basically a variation of the vacuum hood test. Here the test objects are placed in a vessel which is pressurized with the search gas – preferably helium. At a fairly high search gas pressure and after a period of up to several hours it is tried to enrich the search gas inside leaky test objects. This is the actual so called “bombing” process.

After this, the test objects are transferred to a vacuum chamber and their total leak rate is determined in the same way as in the vacuum hood test. During evacuation of the vacuum chamber down to the required testing pressure, those test objects which have a gross leak already lost their accumulated search gas. These parts are not detected as leaking during the actual leak test. Therefore the test with the vacuum chamber is often preceded by a “bubble test”.

This method permits the detection of the lowest leak rates and is used mainly in automatic industrial leak testing especially when it is not possible to fill the parts with gas in any other way.

Key to the Figures

- | | | |
|-----------------|-----------------------|-----------------|
| 1 Test object | 3 Search gas cylinder | 5 Hood |
| 2 Leak detector | 4 Vacuum pump | 6 Sniffer probe |

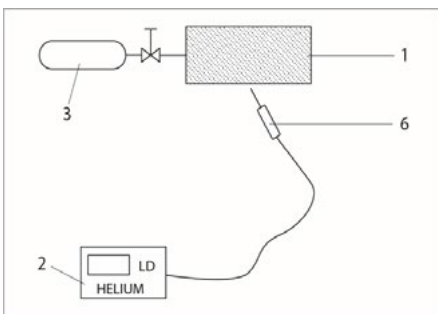

Local leak detection –
Search gas overpressure in the test object

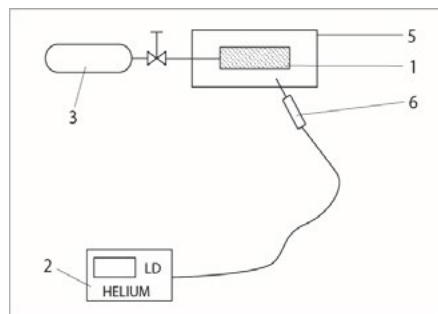

Integral method (search gas accumulation)
Search gas overpressure in the test object

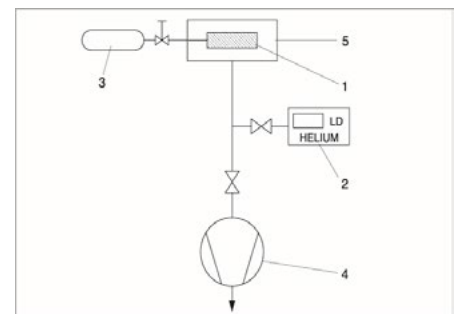

Integral method –
Search gas overpressure in the test object

Operating Principles of the Helium Leak Detectors

Operating Principle

A helium leak detector performs the localization of leaks and the quantitative determination of the leak rate, i.e. the gas flow through the leak. Such a leak detector is therefore a helium flow meter.

In practice the leak detector performs this task by firstly evacuating the part which is to be tested, so that gas from the outside may enter through an existing leak due to the pressure difference present. If only helium is brought in front of the leak (for example by using a spray gun) this helium flows through the leak and is pumped out by the leak detector. The helium partial pressure present in the leak detector is measured by a sector-mass spectrometer and is displayed as a leak rate. This is usually given in terms of volume flow of the helium (pV-flow).

Important Specifications

The two most important features of a leak detector are its measurement range (detection limits) and its response time.

The measurement range is limited by the lowest and the highest detectable leak rate. The lowest detectable leak rate is defined by the sum of drift and noise in the most sensitive measurement range. Usually the sum of noise amplitude and zero drift per minute is made to be equivalent to the lowest detectable leak rate. With leak detectors the amount of drift is so low, that the noise amplitude alone determines the detection limit.

The highest detectable leak rate depends strongly on the method employed. Especially the counterflow method and partial flow operation (see description below) perform with the measurement of very high leak rates even with a sensitive helium leak detector. In addition the multistage switchable high impedance input amplifiers of the leak detectors

also perform with the measurement of high leak rates.

In practical applications, especially in the localization of leaks the response time is of great significance. This is the time it takes from spraying the test object with helium until a measured value is displayed by the leak detector. The response time of the electronic signal conditioning circuitry is an important factor in the overall response time. In the case of leak detectors the response time of the electronic circuitry is well below 1s.

The volume flow rate for helium at the point of the test object is of decisive significance to leak detection on components which are pumped down solely by the leak detector. This volume flow rate provided by the leak detector takes care of the helium entering through a leak and it ensures quick detection by the leak detector. On the other hand the volume of the test object delays the arrival of the helium signal. The response time can be calculated on the basis of the following simple equation:

$$\text{Response time for helium } t_A = 3 \frac{V}{S_{He}}$$

(for 95% of the final value)

with V = Volume of the test object

S_{He} = Volume flow rate for helium at the point of the test object

(or at the inlet of the leak detector, if it alone pumps down the test object).

Main Flow Method

This operating principle of helium leak detectors is based on the main flow method and was long time the classic method of leak detectors. Here the entire helium flow passes through the high vacuum system of the leak detector, where the mass spectrometer measures the partial pressure of the helium. In this, the use of a liquid nitrogen cold trap is essential to remove water vapor or other condensable gases in the vacuum system which impair the operation. Moreover, the use of a cold trap performs the low operating pressures for the mass spectrometer to be reached (below 10^{-4} mbar) despite the directly connected (and possibly contaminated) test object.

The advantages of the main flow method are:

- Highest sensitivity, i.e. low detection limit
- Short response time due to a high volume flow rate at the inlet.

The disadvantage of the main flow method is that the gas flow is being led through the mass spectrometer thus particles like dust and dirt penetrate into the measuring system and may disturb the helium measurements.

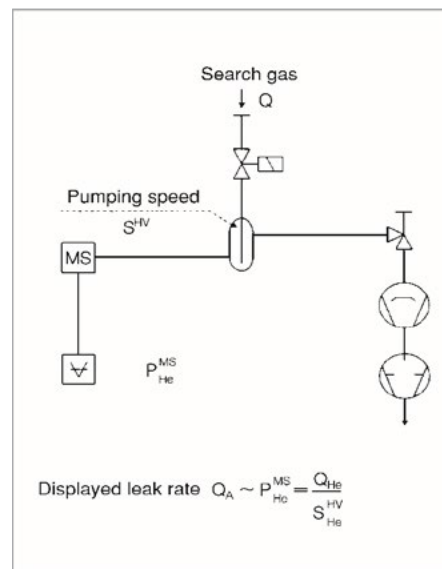

Main flow method

Counterflow Method

With this method the test object is not connected to the high vacuum. Instead it is connected to the forevacuum (between turbomolecular pump and backing pump), so that the entire gas flow (especially water vapor) does not contribute to the pressure increase in the mass spectrometer. Thus a cold trap is no longer required!

The helium which now enters the forevacuum can still be detected, as it is able to flow against the pumping direction of the turbomolecular pump into the mass spectrometer. This is due to the high particle velocity of the helium. The sensitivity of this counterflow arrangement is equal to that of the main flow principle, provided the right combination of volume flow rate of the backing pump and helium compression of the turbomolecular pump is used.

The advantages of the counterflow method are:

- No liquid nitrogen is required
- High permissible inlet pressures (i.e. pressure within the test object)

This makes the counterflow method especially suitable for mobile leak detection on systems. For leak detection on larger components where a short response time is essential (i.e. high volume flow rate) an additional turbomolecular pump stage is required at the inlet of the leak detector.

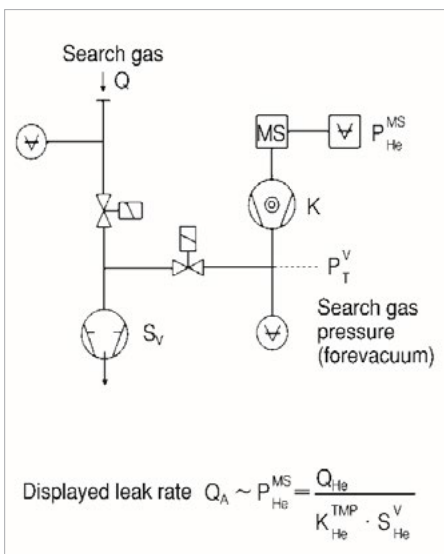

Counterflow method

Partial Flow Method

In order to expand the measurement range in the direction of higher leak rates and for operation at higher inlet pressures, helium leak detectors incorporate a partial flow or a gross leak system. This consists basically of a throttle and a rotary vane pump. At pressures above the normal inlet pressure (main flow: above 10^{-2} mbar, counterflow: above 10^{-1} mbar) or in the case of high helium leak rates, the inlet valve is closed and the main flow is allowed to enter the partial flow pump, whereas only a small part enters the leak detector via the partial flow throttle. Thus the total pressure and the helium pressure are dropped to values suitable for operation of the leak detector.

To obtain correct leak rate readings in the partial flow mode, the partial flow ratio, i.e. the ratio between the actually measured gas flow and the total gas flow must be known and stable.

In all leak detectors this is achieved by a partial flow throttle made of ruby with a precisely machined hole. This ensures that the quantitatively determined leak rates are always correct without calibration, even for gross leaks.

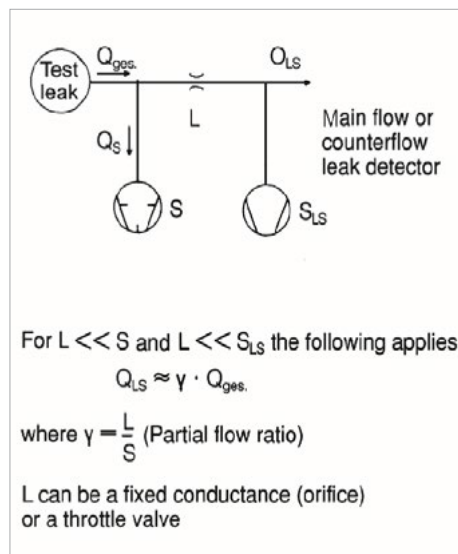

Partial flow method

Calibration of Helium Leak Detectors with Calibrated Leaks

In the process of leak detection one expects that a test object which does not have a leak produces a zero reading on the leak detector. In this any malfunctions are excluded. Thus calibrated leaks, i.e. artificial leaks which produce a known helium leak rate are essential for reliable results.

To obtain a quantitatively correct leak rate reading the sensitivity of the leak detector must also be adjusted. This requires the use of a calibrated leak.

Leybold offers calibrated helium leaks of various designs covering the range between 10^{-9} to 10^{-4} mbar x l/s as part of the standard range of products. All leak rates are traceable to the standards of the DAkkS Calibration Service controlled by the PTB (Federal Institution of Physics and Technology).

If requested each helium calibrated leak can be supplied with a calibration certificate issued by the DAkkS Calibration Service. The calibration itself is performed by the DAkkS Calibration Service for Vacuum which is run by Leybold on behalf of the PTB.

Products

Fourth PHOENIX Generation

The PHOENIX 4 family sets new standards in helium leak detection.

The product portfolio provides the perfect device for a variety of applications.

The PHOENIX Quadro – as a universal, portable helium leak detector is the all-rounder in its class.

PHOENIX Quadro Dry Plus - the only dry

premium leak detector on the market without diaphragm pump - designed for accurate and reliable performance.

Full flexibility is achieved with the PHOENIX Vario, which knows to convince with its unique compactness and free selection of the backing pump that is to be connected.

All versions are suited for the use in vacuum as well as sniffer operation.

The PHOENIX Portable Helium leak detectors range is available with oil-sealed or dry running backing pump as well as in a variety of different voltage versions.



PHOENIX Quadro



The PHOENIX Quadro is a portable helium leak detector, which can be used in many different applications. The accurate measuring system and the intuitive operation of the PHOENIX Quadro ensure simple and highly reliable leak detection. The PHOENIX Quadro Dry Plus has a dry-running backing pump and thus features no helium accumulation and superior pumping speed.

When it comes to applications that require oil-free pumping, the PHOENIX Quadro Dry Plus is therefore the ideal choice for reliable and efficient leak detection.

Advantages to the User

- Detects even the smallest leak quickly and reliably
- Very fast operational readiness
- Extremely short response times
- Rapid decontamination time in case of helium contamination
- Very high detection sensitivity
- Convenient remote control via smartphone or tablet PC without software installation
- Variety of interfaces for optimal device communication
- Innovative color touch display
- Long life span of the components
- Oil-free pumping system with the PHOENIX Quadro Dry Plus
- Internal data memory as well as simple data output via USB

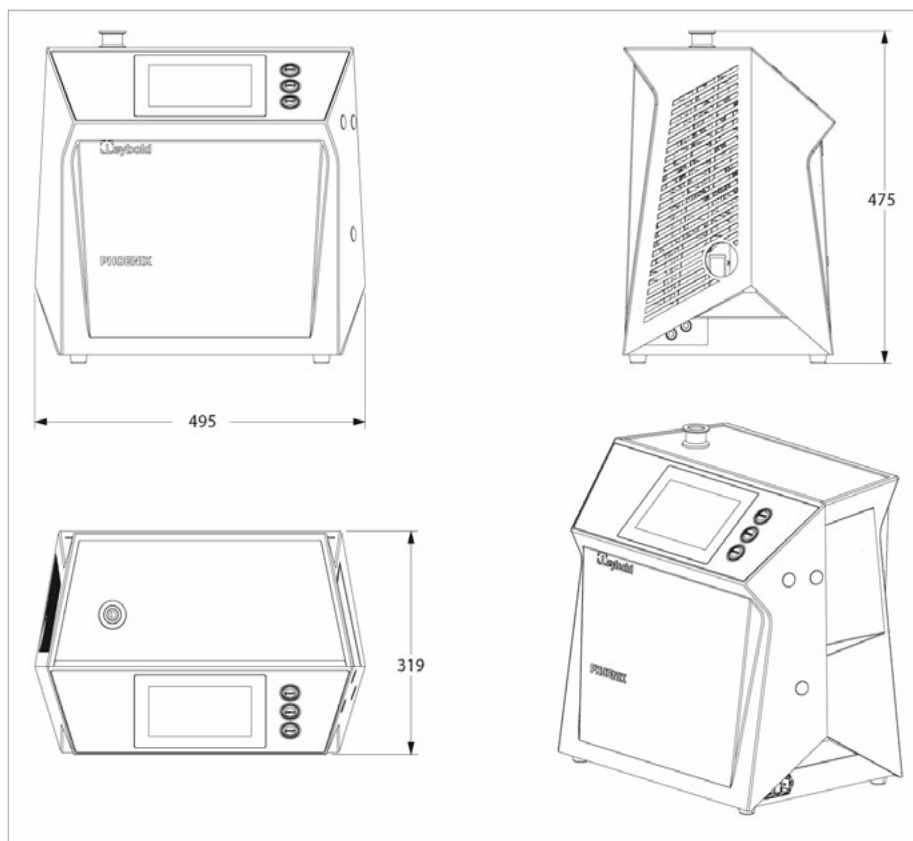

Dimensional drawing PHOENIX Quadro (Dimensions in mm)

Technical Data

PHOENIX 4

Quadro

Quadro Dry Plus

Minimum detectable helium leak rate			
Vacuum mode	mbar x l/s	$\leq 5 \times 10^{-12}$	
Sniffer mode	mbar x l/s	$< 1 \times 10^{-9}$ ¹⁾	
Minimum detectable hydrogen leak rate			
Vacuum mode	mbar x l/s	$\leq 1 \times 10^{-8}$	
Sniffer mode	mbar x l/s	$< 1 \times 10^{-7}$	
Units of measurement (selectable)		mbar, Pa, atm, Torr	
Pressure		mbar x l/s, Pa x m ³ /s, Torr x l/s, atm x cc/sec, sft ³ /yr	
Leak rate		ppm, g/a eq, oz/yr eq	
Sniffer mode			
Leak rate measurement range	mbar x l/s	1×10^{-12} to 1×10^{-1}	
Measurement ranges		12 decades	
Max. inlet pressure	mbar (Torr)	15 (11.25)	
Pumping speed during the evacuation process			
50 Hz	m ³ /h (cfm)	2.5 (1.5)	3.4 (2.0)
60 Hz	m ³ /h (cfm)	3.0 (1.8)	3.8 (2.2)
Pumping speed (helium) at the inlet			
FINE mode	l/s	1.2	1.2
ULTRA modes	l/s	> 3.1	> 3.1
Time constant of the leak rate signal (blanked off, 63% of final value)	s	< 1	
Run-up time (after starting)	s	≤ 110	
Mass spectrometer		180° magnetic sector field	
Ion source		2 filaments; iridium/yttria-oxide	
Detectable masses	amu	2, 3 and 4	
Inlet port	DN	25 ISO-KF	
Dimensions (W x H x D)	mm	495 x 475 x 318	
Weight	kg (lbs)	41 (90)	42 (93)
Available languages		English, German, Chinese, Japanese (Katakana), Korean, Russian, French, Italian, Spanish and Polish	

Ordering Information

PHOENIX 4

Quadro

Quadro Dry Plus

	Part No.	Part No.
PHOENIX Quadro EURO version 230 V, 50/60 Hz	250000V02	250003V03
PHOENIX Quadro US version 115 V, 60 Hz	251000V02	251003V03
PHOENIX Quadro Japan version 100 V, 60 Hz	251100V02	251103V03

¹⁾ Depending on the used sniffer line and site conditions. Leakage rate signal after zero: 1×10^{-8} mbar x l/s when using the sniffer line SL 300 or SL 301

For further accessories see para. "Accessories for PHOENIX Quadro, PHOENIX Magno and PHOENIX Vario"

PHOENIX Vario



The PHOENIX Vario has no built-in backing pump, and therefore has the smallest installation space with maximum flexibility. The type and size of the backing pump can be chosen freely depending on applications and process requirements.

The PHOENIX Vario thus combines the excellent properties of the PHOENIX 4 series with the required pumping system. In that way both oil-sealed and dry backing pumps can be selected and the fore vacuum suction capacity can be adapted perfectly to the target application.

Advantages to the User

- Application-optimized pumping speed
- Extremely small installation space
- Very light weight
- Highly reliable measuring system
- Simple, intuitive handling
- Very high detection sensitivity
- Convenient remote control via smartphone or tablet PC without software installation
- Variety of interfaces for optimal device communication
- Innovative color touch display
- Extremely short response times
- Internal data memory as well as simple data output via USB

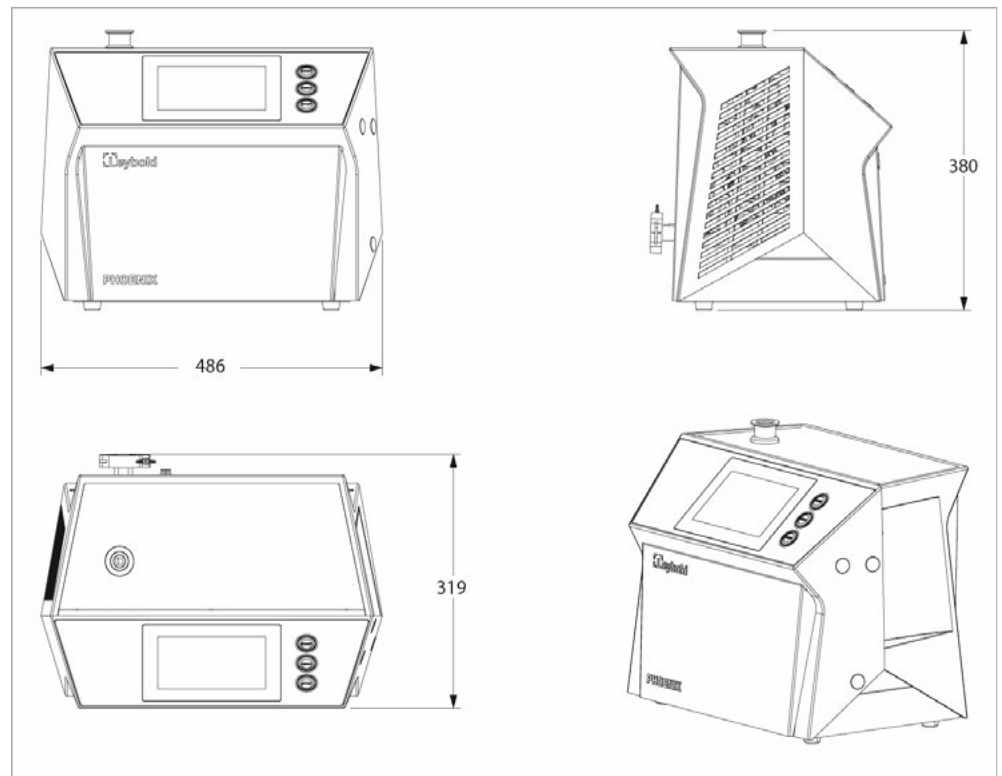

Dimensional drawing PHOENIX Vario (Dimensions in mm)

Technical Data

PHOENIX Vario

Minimum detectable helium leak rate		
Vacuum mode	mbar x l/s	$\leq 5 \times 10^{-12}$
Sniffer mode	mbar x l/s	$< 1 \times 10^{-9}$ ¹⁾
Minimum detectable hydrogen leak rate		
Vacuum mode	mbar x l/s	$\leq 1 \times 10^{-8}$
Sniffer mode	mbar x l/s	$< 1 \times 10^{-7}$
Max. inlet pressure		15 (11.25)
with partial flow pump set	mbar (Torr)	1000 (750)
Pumping speed (helium) at the inlet		
ULTRA modes	l/s	> 3.1
Time constant of the leak rate signal (blanked off, 63% of final value)		< 1
Units of measurement (selectable)		
Pressure		mbar, Pa, atm, Torr
Leak rate		mbar x l/s, Pa x m3/s, Torr x l/s, atm x cc/sec, sft3/yr
Sniffer mode		ppm, g/a eq, oz/yr eq
Leak rate measurement range		1×10^{-12} to 1×10^{-1}
Run-up time (after starting)		≤ 2
Mass spectrometer		180° magnetic sector field
Ion source		2 filaments; iridium/yttria-oxide
Detectable masses		2, 3 and 4
Test port		1 x DN 25 ISO-KF
Dimensions (W x H x D)		486 x 380 x 313
Weight		25 (55.12)
Available languages		English, German, Chinese, Japanese (Katakana), Korean, Russian, French, Italian, Spanish and Polish

¹⁾ Depending on the used sniffer line and site conditions. Leakage rate signal after zero: 1×10^{-8} mbar x l/s when using the sniffer line SL 300 or SL 301

For further accessories see para. "Accessories for PHOENIX Quadro and PHOENIX Vario"

Ordering Information

PHOENIX Vario

	Part No.
PHOENIX Vario	250002V02

Recommended backing pumps for PHOENIX Vario

The PHOENIX Vario can be operated with any backing pump, allowing full flexibility for the fore vacuum suction capacity.

Fore vacuum pumps that are electrically controllable, can be operated directly via the PHOENIX Vario.

A prerequisite for this is a minimum final vacuum pressure of 2 mbar and a maximum current of 12 A.

Fore vacuum pumps that are not electrically controllable, require a separate power supply.

Ordering Information

High Voltage 230 V, 50 Hz

Low Voltage 100 V, 50/60 Hz

	Part No.	Part No.
Recommended backing pumps, electrically controlled		
TRIVAC D 4 B	11245	140081
TRIVAC D 8 B	11255	140082
TRIVAC D 16 B	11265	-
TRIVAC D 25 B	11275	-
SOGEVAC SV 16 D	960186V	960186V
SOGEVAC SV 28 BI	960277	960278
SOGEVAC SV 40 BI FC	960364V	-
SCROLLVAC 7 plus	141007V10	141007V10
SCROLLVAC 10 plus	141010V10	141010V10
SCROLLVAC 15 plus	141015V10	141015V10
SCROLLVAC 18 plus	141018V10	141018V10
Recommended backing pumps, separate electrical supply		
ECODRY 40 plus	161040V01	-
ECODRY 65 plus	161065V01	-

For further accessories see para. "Accessories for PHOENIX Quadro, PHOENIX Magno and PHOENIX Vario"

Mobile Leak Detection Systems

PHOENIX 4 Cart



The PHOENIX 4 Carts, with their wide range of possible combinations, are the right solution for applications when a mobile helium leak detection system is required: PHOENIX 4 Carts are easily configured, come assembled and ready for connection and leak testing. Plug in and switch on, for highest reliability and measuring accuracy from the start.

The PHOENIX 4 Carts can be configured as follows

- PHOENIX 4 Leak Detector Model of choice
- Choice of oil-sealed or oil-free fore vacuum system
- Mobile cart with handle, accessory drawer, swivel castors and two types of wheels of your choice
- Partial flow system

Leak detectors of the PHOENIX 4 series set standards in helium leak testing. The large model portfolio offers the perfect instrument for every application. Advantages include fast readiness for measurement, precise and reliable

measurements with high detection sensitivity, the intuitive HMI with easy touch screen control, an integrated web server for easy remote control with any internet-capable mobile device and easy internal and external data recording via USB.

PHOENIX 4 are optimal leak detectors for demanding leak testing in vacuum or sniffer applications. With a minimum detectable leak rate of 5×10^{-12} mbar l/s, the PHOENIX 4 reliably detects even the smallest leaks under poor conditions, thus ensuring high process reliability.

For applications that require an oil-free pumping system, PHOENIX 4 Cart systems are available with dry-running fore vacuum pumps in various pumping speed classes instead of oil-sealed ones. Versions for EU, US and JP mains voltages are also available.

PHOENIX 4 Carts with partial flow system are ideal for larger test volumes or for leak detection in harsh environments. Significantly faster pump-down time and measurement readiness from

an inlet pressure of 1000 mbar and the faster ventilation of large test objects ensures a high throughput.

The robust and user-friendly design is designed for a long service life.

Technical Data

PHOENIX 4 Cart

Power supply voltage			
EU version	V		230 / 50 Hz
US version	V		120 / 60 Hz
Japan version	V		120 / 50/60 Hz
Protection level	IP		20
Noise level	dB(A)		≤ 57
Max. height NHN	m		2 000
Max. rel. atmospheric humidity	%		80 at 30° C, linear decreasing to 50 at 40° C
Storage temperature	°C		-10 to +60
Operating temperature	°C		+10 to +40
Polution degree			2
Weight (without gas cylinder)			
Vario Standard	kg		73
Vario big castors	kg		97
Quadro Standard	kg		98
Quadro big castors	kg		122
Gas cylinder			
Max. bottle size	l		20
Outer diameter	mm		204
Length with cap	mm		970
Wight	kg		38
Inlet			DN 25 ISO-KF

Ordering Information

PHOENIX 4 Cart

PHOENIX Type		CART	Voltage		Fore Vacuum Pump			
Vario	250002				None	0	D 25 B	1
Quadro EU	250000				TRIVAC	1	D 16 B	2
Quadro US	251000		US (120V/60Hz)	1	SOGEVAC	2	Neo D 16	1
Quadro JP	251100		EU (230V/50Hz)	2	SCROLLVAC	3	Neo D 25	2
Quadro Dry+ EU	250003	C	JP (100V/50Hz/60 Hz)	3	ECODRY	4	SC 15 plus	1
Quadro Dry+ US	251003						SC 18 plus	2
Quadro Dry+ JP	251103						ED 65 plus	1
							ED 40 plus	2
							ED 35 plus	3
							ED 25 plus	4
Part No.		250000	C	2	1	1	1	1 *
		Partial Flow		Cart Castors				
		None	0	Standard	0			
		DN 25	1	Big Castors	1			

* Example for a PHOENIX Quadro EU with the partial flow and the TRIVAC D 25 B on the big-wheeled cart

Note: Combination possibilities are subject to technical compatibilities.

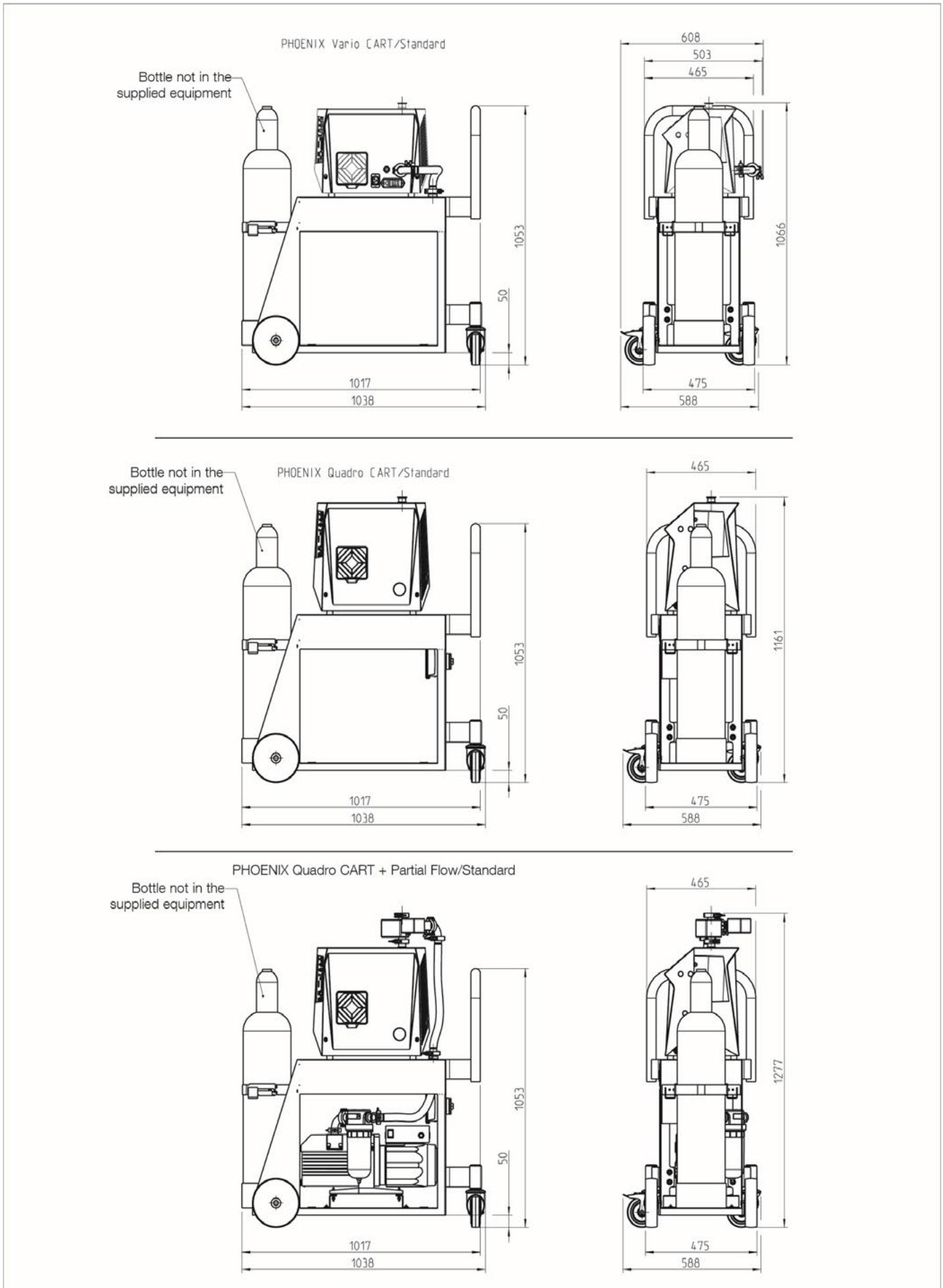

Dimensional drawing PHOENIX 4 Cart with standard castors (Dimensions in mm)

PHOENIX Vario CART/Off-Road

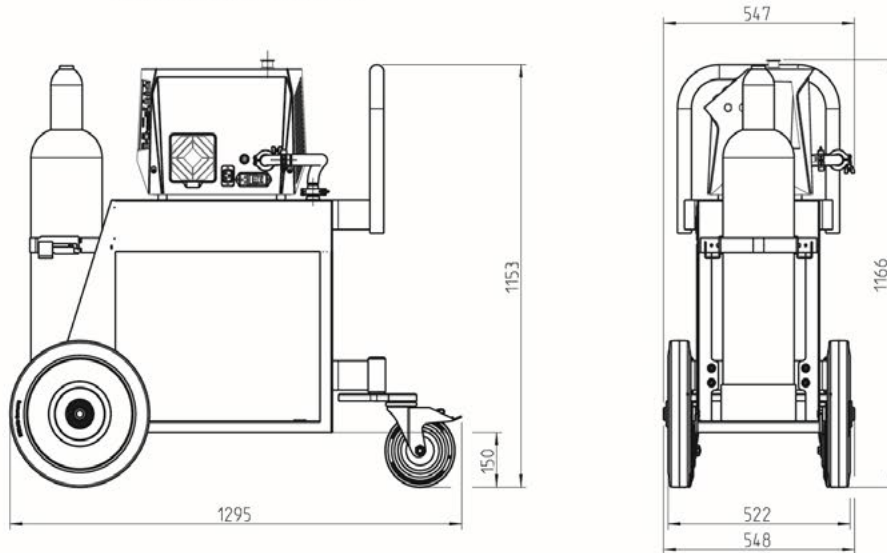

PHOENIX Quadro CART/Off-Road

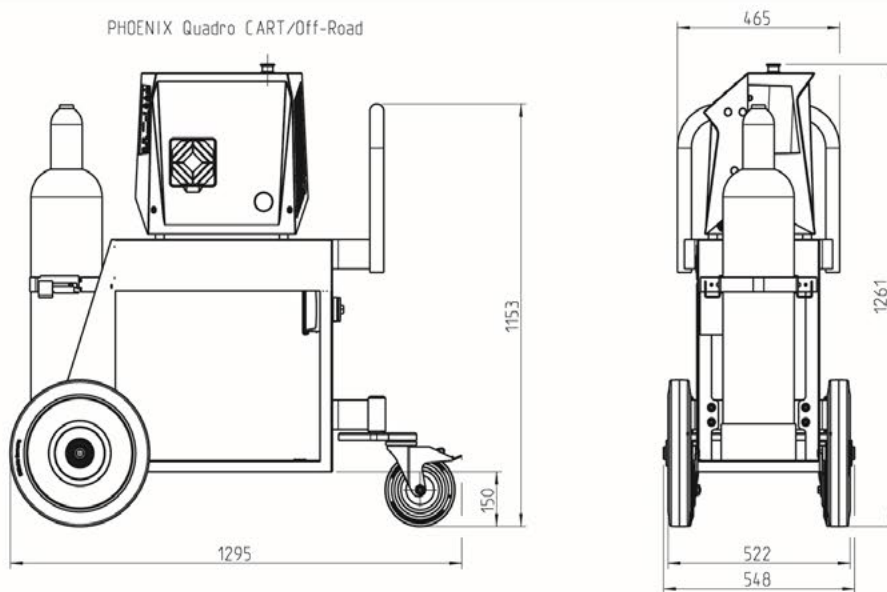

PHOENIX Quadro CART + Partial Flow/Off-Road

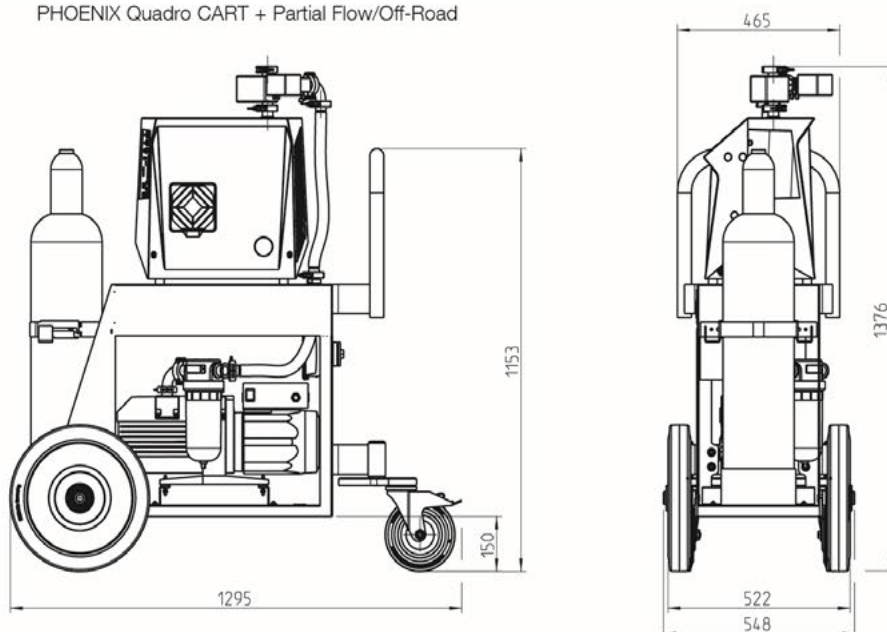

Dimensional drawing PHOENIX 4 Cart with standard castors (Dimensions in mm)

Accessories

Accessories for PHOENIX Quadro and PHOENIX Vario

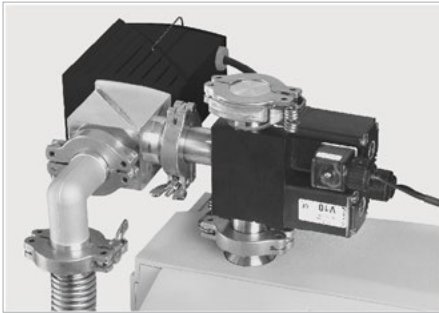

Partial flow system without pump



Search gas spray gun



Interface module



PHOENIX Transport Case



PHOENIX Vario Connector



PHOENIX IO Adapter Cable to L300i

Partial Flow System

with following advantages:

- Faster response
- Start of measurement mode already at 1000 mbar inlet pressure.
- Faster venting of large test objects or leak detection of mass production.

Equipment:

Valve block (with inlet valve, venting valve, bypass or purging valve) plus right-angle bellows valve DN 25 ISO-KF made of stainless steel, solenoid drives, suited for remote control by the PHOENIX.

The partial flow systems are available without pumps.

PHOENIX Transport Case

For impact protected transportation of the PHOENIX; complete with strong carrying handles and plastic castors. Separate case for accessories.

Search Gas Spray Gun

The search gas spray gun with PVC hose (5 m long) is used for well aimed spraying of search gas at places where a leak is suspected.

PHOENIX Vario connector

A matching connector for the electrical connection between the leak detector and fore vacuum pump is available in order to control the vacuum pump directly via the PHOENIX Vario.

PHOENIX Wi-Fi Antenna

The PHOENIX Quadro series can be controlled conveniently via any mobile terminal such as tablet PC or smart-phones, without the installation of a software or app.

In order to be able to use the Wi-Fi function, a compatible PHOENIX Wi-Fi antenna needs to be connected to the PHOENIX USB port. Available antennas vary by region. For further information and assistance please contact our customer support.

PHOENIX interface modules for the use of further interfaces.

The modules can be placed on the device or mounted in a control cabinet or similar by the customer via a cable connection.

The appropriate cables are available in various lengths.

The PHOENIX IO interface features the following:

- PLC IN
- PLC OUT
- ANALOG OUT
- RS232

The PHOENIX bus interface is available for:

- Profibus
- ProfiNet
- DeviceNet
- Ethernet I/P

PHOENIX IO Adapter Cable to L300i

The IO Adapter allows a plug-and-play solution for the use of PLC / recorder output with the existing L300i plug, when switching from PHOENIX L300i to PHOENIX 4.

Ordering Information

Accessories

	Part No.
Transport Case PHOENIX Quadro	252004V02
Transport Case PHOENIX Vario	252024V02
Partial flow system ¹⁾	
PHOENIX 200-240V	14020V01
PHOENIX 100-120V	14020V02
AF 16-25 exhaust filter, for partial flow system	18911
Search gas spray gun	16555
PHOENIX IO Interface	252211V02
PHOENIX Bus Interface Profibus	252212V02
PHOENIX Bus Interface ProfiNet	252213V02
PHOENIX Bus Interface DeviceNet	252214V02
PHOENIX Bus Interface EtherNet/IP	252215V02
PHOENIX Vario connector plug	252300V02
Cable for PHOENIX Interface modules – 0.5 m	252293V02
Cable for PHOENIX Interface modules – 2 m	252290V02
Cable for PHOENIX Interface modules – 5 m	252291V02
Cable for PHOENIX Interface modules – 10 m	252292V02
PHOENIX IO Adapter cable to L300i	252400V02

¹⁾ 5 centering rings, 5 clamping rings and 1 vacuum hose 1 m with DN 25 ISO-KF are included

CART for PHOENIX Quadro and PHOENIX Vario



The CART for the PHOENIX 4 allows maximum mobility of the leak detector with all required accessories. The high-quality construction thus provides work surfaces for test leaks, as well as the flexible mounting possibility of helium bottles of various sizes. Furthermore, external fore vacuum pumps can also be mounted via a flexible rail construction in the lower level. Due to the innovative design, the helium supply is located on the side facing away from the inlet of the leak detector. Large stable rollers ensure easy transportation and mobility of the leak detector structure.

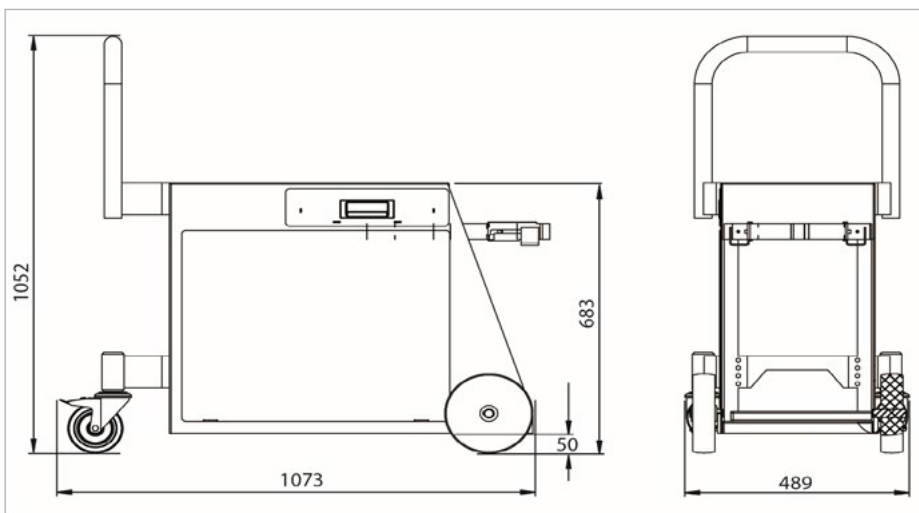

Technical Data

CART

Dimensions (L x W x H)	mm	489 x 1052 x 1073
------------------------	----	-------------------

Ordering Information

Cart

	Part No.
CART PHOENIX 4 for PHOENIX Quadro and PHOENIX Vario	252005V02

RC 310 C / RC 310 WL

Remote Control Units for Leak Detectors



Wired remote control unit RC 310 C



Wired remote control unit RC 310 C

The RC 310 remote control unit with their industrial design RC 310 WL (wireless) and RC 310 C (cable) and integrated data memory offer utmost flexibility during the leak detection process.

The RC 310 WL permits wireless remote monitoring up to a distance of 100 m. The RC 310 units support the current leak detectors of the PHOENIX 4 series as well as the L300i, UL 200 and L 200 models.

Advantages to the User

- Easy operation via Touch Screen Panel 3.5"
- Wireless transmission up to 100 m, wired transmission up to 34 m
- Data transfer to Windows is possible
- Data backup on internal 32 MB data logger or USB stick is possible
- Possible operating with or without cable
- Adjustable alarm trigger
- Magnetic holder on the rear of the instrument
- Rugged industrial design with an IP 42 rating
- Scroll function for measured data (optional)
- USB connection for data transfer and software updates
- Adjustable loudspeaker and headphone output
- Search function (paging) via audible signal
- Peak hold (maximum value indication)
- For simultaneous detection of up to 10 leak detectors

Typical Application

- Mobile use with a portable leak detector due to wireless link
- Leak detection for analytics
- Medicine technology
- Solar systems
- Research and development
- Vacuum equipment
- Accessories for the automotive industry
- IT branch
- Process industry



Different color displays on the remote control unit

Technical Data

RC 310

Display		TFT graphic touch panel 1/4 VGA / 3.5"; 240 x 320 px
Memory capacity		
Internal memory capacity	MB	64
of this available for recording data	MB	32
or memory stick		
Battery operating time (RC 310 WL only), (depending on charging condition)	hours	> 8
Wireless transmission range RC 310 WL	m	up to 100
HF output power (4 mW)	dBm	+6
Wireless transmission frequency RC 310 WL	GHz	2.4
Audio alarm at 1 m distance, max.	dB(A)	70
Headphone jack stereo 3.5 mm	Ohm	> 2 x 32
Permissible ambient temperature	°C	+5 to +40
Battery charger		
Mains voltages	V	100 – 240 (± 10%)
Frequencies	Hz	50/60
Connectable leak detectors		PHOENIX 4 series, L300i series, UL 200 series, L 200 series
Detection of leak detectors		up to 10
Available languages		English, German
Further languages		Chinese, Japanese (Katakana), Russian, French, Italian, Spanish and Polish
Protection class	IP	42
Charger protection class	IP	56
RC 310 WL radio perwiths		CE, FCC, IC, TELEC, MIC, MII
Dimensions (L x W x H)	mm	210 x 90 x 45
Weight		
RC 310 C, approx.	kg (lbs)	0.4 (0.88)
RC 310 WL, approx.	kg (lbs)	0.5 (1.1)

Ordering Information

RC 310

	Part No.
Remote control	
RC 310 C, wired with 4 m long connection cable	252013V01
RC 310 WL, wireless with battery charger (for integrated rechargeable battery) and wireless transwithter with connection cable (additional 4 m long connection cable)	252014V01
Accessories	
Wireless transwithter with connection cable (for operation of a further PHOENIX Quadro)	252015V01
Extension cable, 10 m (three extensions max. are possible)	14022

Helium Sample Probes (Sniffers)

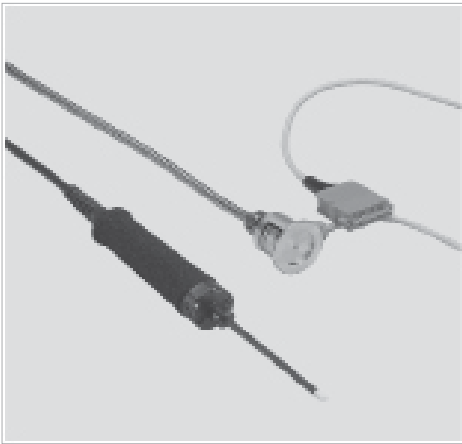

Helium sniffer line SL 300



Helium sniffer QUICK-TEST QT 100 with sniffer

Helium sniffers in connection with the leak detectors are used for leak testing test samples in which a helium overpressure is present. Besides accurate pinpointing of leaks it is also possible to determine the leak rate of the escaping helium.



Helium sniffer line SL 301 in transport case

Advantages to the User

Helium Sniffer Line SL 300 and SL 301

- Sniffer line connects directly at the test connection
- **SL 300**
Comfortable helium sniffer with red and green status LED and ZERO push-button
- **SL 301**
Robust and easy helium sniffer in practical transport case
- Easy filter removable
- Very fast response
- Extremely low detection limit with $< 1 \times 10^{-7}$ mbar x l/s
- Rigid sniffer tip 120 mm
- Very rugged industrial design

Helium Sniffers QUICK-TEST QT 100

- Sniffer leak detection for greater distances between test object and leak detector
- Diaphragm pump for sucking the search gas
- Smallest detectable leak rate 1×10^{-6} mbar x l/s
- Short response and decay times
- High sniffer velocity
- Switching power supply, can be run off mains voltages from 100 to 230 V AC

Typical Applications

- Storage and transportation vessels for gases and liquids
- Gas supply systems
- Gas compressors
- Components for the cooling and air conditioning industries
- Heat pumps and components for thermal energy recovery units
- Chemical production plants
- Supply and phone lines laid in the ground
- Power station condensers and turbines
- Window and door seals of car bodies, refrigerators and alike
- Revision checks on leak testing systems
- Measurement of helium concentrations ranging from ppm to %
- All hollow objects exposed to overpressures

Technical Data

SL 300 / SL 301

QT 100

Smallest detectable leak rate	mbar x l/s	< 10 ⁻⁷	10 ⁻⁶
Inlet pressure	mbar	< 0.13	–
Supply voltage		–	100 – 230 V, 50/60 Hz
Signal response time for			
SL 301 at a length of			
4 m	s	< 1	–
10 m	s	< 4	–
SL 300 at a length of			
4 m	s	< 1	–
20 m	s	–	< 6
50 m	s	–	20
Connection flange	DN	25 ISO-KF	
Weight	kg (lbs)	0.6 (1.3)	3.5 (7.7)

Ordering Information

SL 300 / SL 301

	Part No.
Helium sniffer line with rigid sniffer tip 120 mm SL 300 red/green LED ZERO button 4 m long, straight handle	252003
SL 301 4 m long, straight handle	252025V01
10 m long, straight handle	252026V01
Spare Parts for SL 301 Filter insert, 2 pieces	ESLMSA-92097
Stainless steel tube with capillary tube	E-LST-30

Ordering Information

QT 100

	Part No.
Helium sniffer QUICK-TEST QT 100	15594
Sniffer line for the QT 100	
5 m	14008
20 m	14009
50 m	12183

Calibrated Leaks for Vacuum and Sniffer Applications



Test leaks

Calibrated Leaks for Vacuum Applications

TL 4 and TL 6

Calibrated leaks without gas reservoir (capillary type of leak) for sensitivity and signal response time determinations during vacuum leak detection and for determination of sniffer sensitivity for overpressure leak detection. Nominal leak rate ranges 10^{-4} mbar x l/s for TL 4 and 10^{-6} mbar x l/s for TL 6. Suitable for helium. A purging valve with hose nozzle provides a rapid exchange of the gas in the dead volume.

TL 4-6

Helium calibrated leak (capillary leak) for gross leaks, adjustable in the range between 10^{-4} to 10^{-6} mbar x l/s, with exchangeable helium reservoir, pressure gauge and two manually operated valves. For calibration of leak rate readings and the alignment of helium mass spectrometers in the vacuum pressure range and for determining the sensitivity of sniffers in the overpressure range.

TL 4

Calibrated helium leak (capillary leak) with reservoir which may be refilled and with a leak rate in the range of 10^{-4} mbar x l/s. Special calibrated leak for use in a vacuum.

TL 7 (For installation within the PHOENIX 4)

Helium calibrated leak (capillary leak) with helium reservoir and electromagnetically operated valve. Leak rate range 10^{-7} mbar x l/s. The electromagnetically operated valve provided permits the opening and closing of the calibrated leak to be controlled by the leak detector's software.

TL 7

Calibrated helium leak (capillary leak) with helium reservoir, manual valve and He gas.

TL 8 and TL 9

Helium calibrated leak calibrated for a leak rate in the range of 10^{-8} mbar x l/s (helium leak rate) for TL 8 and 10^{-9} mbar x l/s for TL 9, with gas reservoir and diaphragm shutoff valve. For alignment of a helium mass spectrometer, for calibration of the leak rate display of helium leak detectors and for response time measurements in connection with larger volumes.

Note

All calibrated leaks with the exception of the TL 4 are not suited for use in a vacuum.

Calibrated leaks are required for the alignment of mass spectrometers, for the calibration of leak rates and for determining the response time of vacuum systems.

Advantages to the User

- Inspection certificate (included) in accordance with DIN EN 10204-3.1
- Highly accurate
- Very low temperature dependence
- Determination of the nominal leak rate by comparison with a calibrated leak having a PTB 1) certificate
- DAkkS 2) certificate (optional), traceable to PTB
- Custom models for special applications

The nominal leak rate applies only if the calibrated leak has been connected to a vacuum system at a pressure of less than 1 mbar.

¹⁾ Federal Institution of Physics and Technology

²⁾ Deutsche Akkreditierungsstelle GmbH (German Calibration Service)

Calibrated Leaks for Sniffer

Applications

These calibrated leaks have been set to a fixed value within the typical leak rate range (see Ordering Information). The exchangeable calibration gas reservoir is monitored through the built in manometer.

Helium calibrated leaks

S-TL 4 to S-TL 6 with leak rates from 10^{-4} to 10^{-6} mbar x l/s.

Set of Calibrated Leaks for Power Plants

These three calibrated leaks of 1000, 100 and 10 mbar x l/s allow leak tests under partial flow conditions under the ambient conditions of power plants.

Technische Daten

Leak Rate Range

Leak Detection Method

Connection Flange

Technische Daten	Leak Rate Range	Leak Detection Method	Connection Flange
TL 4, without Helium gas reservoir	10^{-4} mbar x l/s	Vacuum and sniffer	DN 16 ISO-KF
TL 6, without Helium gas reservoir	10^{-6} mbar x l/s	Vacuum and sniffer	DN 16 ISO-KF
TL 4-6, with Helium gas reservoir	10^{-4} to 10^{-6} mbar x l/s	Vacuum and sniffer	DN 16 ISO-KF
TL 4, with Helium gas reservoir	10^{-4} mbar x l/s	Vacuum	Discharging opening
TL 7, with Helium gas reservoir	10^{-7} mbar x l/s	Vacuum (for installation within the PHOENIX)	Nozzle
TL 7, with manual valve and Helium gas reservoir	10^{-7} mbar x l/s	Vacuum	DN 10 ISO-KF
TL 8, with Helium gas reservoir	10^{-8} mbar x l/s	Vacuum	DN 10 ISO-KF
TL 9, with Helium gas reservoir	10^{-9} mbar x l/s	Vacuum	DN 10 ISO-KF
S-TL 4, with Helium gas reservoir	10^{-4} mbar x l/s	Sniffer	Nozzle
S-TL 5, with Helium gas reservoir	10^{-5} mbar x l/s	Sniffer	Nozzle
S-TL 6, with Helium gas reservoir	10^{-6} mbar x l/s	Sniffer	Nozzle

Ordering Information

Calibrated Leak

	Part No.
TL 4, without Helium gas reservoir ¹⁾	15565
TL 6, without Helium gas reservoir ¹⁾	15566
TL 4-6, with Helium gas reservoir ¹⁾	15580
TL 7, with Helium gas reservoir ¹⁾ for installation within the PHOENIX 4 filling pressure 2,9 bar	14023V01
TL 7, with manual valve and Helium gas reservoir	14210
TL 8, with Helium gas reservoir ¹⁾	16557
TL 9, with Helium gas reservoir ¹⁾	14408
STL 4, with Helium gas reservoir ¹⁾	12237
STL 5, with Helium gas reservoir ¹⁾	12238
STL 6, with Helium gas reservoir ¹⁾	12239
Rubber bladder with hose clamp	89011
Helium can; 1 l, 12 bar (for TL 4-6)	252001

¹⁾ With factory certificate

Screw-in Calibrated Leaks

The manufacturers of helium leak testing systems are in need of calibrated leaks of various sizes with individually adjusted leak rates for the purpose of setting up and calibrating their systems.



Calibrated leak with screw-in sleeve

Calibrated Leak with Screw-in Sleeve

Is used as a so-called master leak to check the entire helium leak testing system.

Generally two leaktight test samples are equipped with these calibrated leaks. These will ensure proper separation between “passed and rejected” parts.

They are fitted to the customer's test samples either by a welded joint or the screw-in sleeve is glued in place.

Typical Applications

- As a master calibrated leak built-in directly into the test sample
- Directly installed to the test chamber
- Use as a calibrated leak for sniffer applications

Depending on the type of application these calibrated leaks are either installed in the test sample as a master leak or used as a continually available facility in the test chamber itself.



Calibrated leak with pin type casing

Calibrated Leak with Pin Type Casing

Serves as a calibrated leak for the entire helium leak testing system without being influenced by the presence of a test sample.

Here a dummy is placed in the test chamber. The connection to the test chamber is directly by a DN 10 ISO-KF fitting. The test gas connection is either by a VCO fitting or a hose nozzle for flexible connections.

Connections on the side of the customer's system are

- 16 ISO-KF running to the vacuum chamber
- Hose nozzle, 10 mm in diameter or VCO fitting, 10 mm in diameter

Advantages to the User

- Various types adapted to different customer requirements
- Simple to operate
- Easy to install

Leybold is offering a complete family of calibrated leaks which are capable of meeting the requirements concerning type and required leak rate.



Calibrated leak with cylindrical casing

Calibrated Leak with Cylindrical Casing

Is used to check the sensitivity of a sniffing facility.

Before and after the actual test, the operator checks the sensitivity of his test facility within the scope of a plausibility check.

The connection on the side of the customer's system is provided via a VCO fitting for a diameter of 10 mm.

- Ideal installation dimensions
- As a rule, all calibrated leaks are supplied with a certificate (factory certificate) indicating the leak rate which has been set up

Customer-specific test leaks

The specified test leaks are customer-specific, which is why the specification of the leakage rate, the test pressure and the type of gas is necessary. The specification is carried out via the test leakage form on the Leybold website → www.leyboldproducts.com/test-leak-form

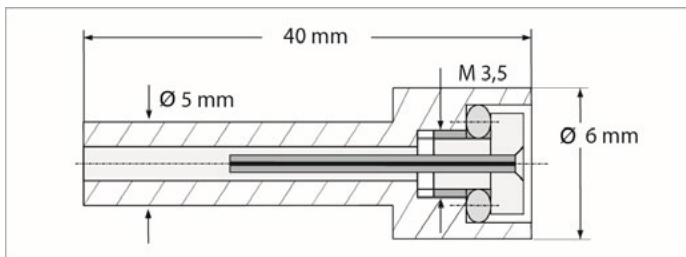

Calibrated leak with screw-in sleeve

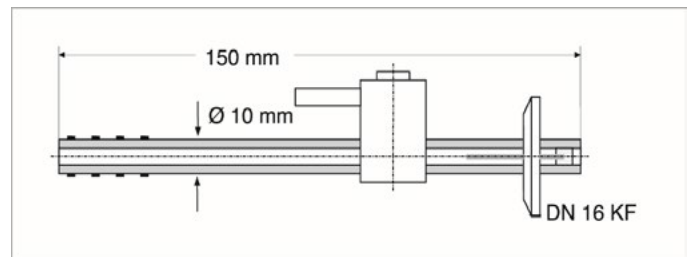

Calibrated leak with pin type casing and hose nozzle

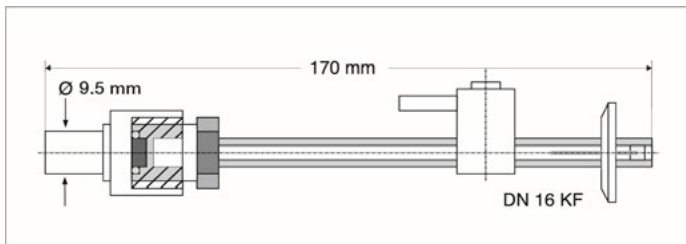

Calibrated leak with pin type casing and VCO fitting

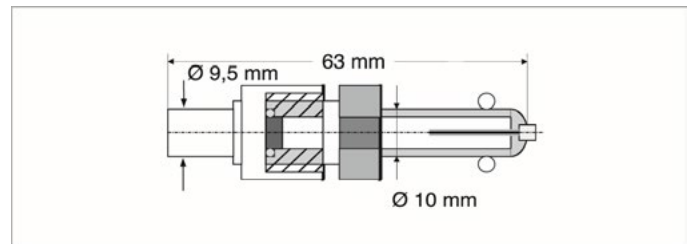

Calibrated leak with cylindrical casing and VCO fitting

Ordering Information ¹⁾

Calibrated Leak

	Part No.
Calibrated leak with screw-in sleeve	14300
with pin type casing and VCO fitting	14304
with pin type casing and hose nozzle	14308
with cylindrical casing and VCO fitting	14312

¹⁾ When ordering please always specify the test leak via the testleak-form and indicate the generated code. Please request form if required.

Miscellaneous

Connection Flanges

Leak Detectors

Helium Sniffers

Calibrated Leaks

PHOENIX Quadro	-	DN 25 ISO-KF	SL 300	-	DN 25 ISO-KF	TL 4	-	DN 16 ISO-KF
PHOENIX Magno	-	DN 25 ISO-KF	QT	-	DN 25 ISO-KF	TL 6	-	DN 16 ISO-KF
PHOENIX Vario	-	DN 25 ISO-KF	ST 100	-	DN 25 ISO-KF	TL 4-6	-	DN 16 ISO-KF

If components of the same nominal width are connected, only one centering ring and one clamping ring will be required.

Connection Components

When wanting to connect accessories (helium sniffer and calibrated leaks) to a leak detector, the following reducers and components may be necessary:

Reduction

Reducers

Centering Rings Stainless steel/FPM

Clamping Rings Aluminium

	Part No.	Part No.		Part No.	
DN 25 ISO-KF / 16 ISO-KF	183 86 (Aluminum) or 885 04 (Stainless steel)	DN 25 ISO-KF, DN 16 ISO-KF,	88347 88346	DN 20 / 25 ISO-KF DN 10 / 16 ISO-KF	18342 18341
DN 40 ISO-KF / 25 ISO-KF	183 87 (Aluminum) or 885 05 (Stainless steel)	DN 40 ISO-KF, DN 25 ISO-KF,	88348 88347	DN 32 / 40 ISO-KF, DN 20 / 25 ISO-KF,	18343 18342
DN 40 ISO-KF / 16 ISO-KF	183 89 (Aluminum) or 885 07 (Stainless steel)	DN 40 ISO-KF, DN 16 ISO-KF,	88348 88346	DN 32 / 40 ISO-KF, DN 10 / 16 ISO-KF,	18343 18341
DN 63 ISO-K / 40 ISO-KF	269 40 (Aluminum) or 887 40 (Stainless steel)	DN 63 ISO-K, DN 40 ISO-KF,	88703 88348	DN 63 / 250 ISO-K, DN 32 / 40 ISO-KF,	¹⁾ 18343

¹⁾ See clamps for ISO-K flanges in the Product Part "Flanges and Fittings"

The following metal hoses are recommended to connect the leak detectors to systems:

Nominal Width

Length

Ordering Information

		Part No.
DN 16 ISO-KF	1.0 m	86801
DN 16 ISO-KF	0.5 m	86791
DN 25 ISO-KF	1.0 m	86803
DN 25 ISO-KF	0.5 m	86793
DN 40 ISO-KF	1.0 m	86805
DN 40 ISO-KF	0.5 m	86795

Further connecting components, like quick clamping rings and other components are described in Product Part "Flanges and Fittings"

Sales and Service

Germany

Leybold GmbH

Bonner Strasse 498
D-50968 Cologne
T: +49-(0)221-347 1234
F: +49-(0)221-347 31234
sales@leybold.com
www.leybold.com

Leybold GmbH Sales Area North

Branch Office Berlin
Industriestrasse 10b
D-12099 Berlin
T: +49-(0)30-435 609 0
F: +49-(0)30-435 609 10
sales.bn@leybold.com

Leybold GmbH Sales Office South

Branch Office Munich
Karl-Hammerschmidt-Strasse 34
D-85609 Aschheim-Dornach
T: +49-(0)89-357 33 9-10
F: +49-(0)89-357 33 9-33
sales.mn@leybold.com
service.mn@leybold.com

Leybold Dresden GmbH Service Competence Center

Zur Wetterwarte 50, Haus 304
D-01109 Dresden
Service:
T: +49-(0)351-88 55 00
F: +49-(0)351-88 55 041
info.dr@leybold.com

Europe

Belgium

Leybold Nederland B.V. Belgisch bijkantoor

Leuvensesteenweg 542
B-1930 Zaventem
Sales:
T: +32-2-711 00 83
F: +32-2-720 83 38
sales.zv@leybold.com
Service:
T: +32-2-711 00 82
F: +32-2-720 83 38
service.zv@leybold.com

France

Leybold France S.A.S.

Parc du Technopolis, Bâtiment Beta
3, Avenue du Canada
F-91940 Les Ulis cedex
Sales and Service:
T: +33-1-69 82 48 00
F: +33-1-69 07 57 38
sales.or@leybold.com
orsay.sav@leybold.com

Leybold France S.A.S.

Valence Factory
640, Rue A. Bergès
B.P. 107
F-26501 Bourg-lès-Valence Cedex
T: +33-4-75 82 33 00
F: +33-4-75 82 92 69
marketing.vc@leybold.comGreat

Great Britain

Leybold UK LTD.

Unit 9
Silverglade Business Park
Leatherhead Road
Chessington
Surrey (London)
KT9 2QL
Sales:
T: +44-13-7273 7300
F: +44-13-7273 7301
sales.ln@leybold.com
Service:
T: +44-13-7273 7320
F: +44-13-7273 7303
service.ln@leybold.com

Italy

Leybold Italia S.r.l.

Via Filippo Brunelleschi 2
I-20093 Cologno Monzese
Sales:
T: +39-02-27 22 31
F: +39-02-27 20 96 41
sales.mi@leybold.com
Service:
T: +39-02-27 22 31
F: +39-02-27 22 32 17
service.mi@leybold.comN

Netherlands

Leybold Nederland B.V.

Floridadreef 102
NL-3565 AM Utrecht
Sales and Service:
T: +31-(30) 242 63 30
F: +31-(30) 242 63 31
sales.ut@leybold.com
service.ut@leybold.com

Russia

Leybold Russia

Vashutinskoe Road 15, Khimki, Mos-
cow region, 141402
Russia
T: +7 495 933 55 50
LeyboldRussia@leybold.com

Switzerland

Leybold Schweiz AG

Hinterbergstrasse 56
CH-6312 Steinhausen
Warehouse and shipping address:
Riedthofstrasse 214
CH-8105 Regensdorf
Sales:
T: +41-44-308 40 50
F: +41-44-308 40 60
sales.zh@leybold.comService:
T: +41-44-308 40 62
F: +41-44-308 40 60
service.zh@leybold.com

Spain

Leybold Hispánica, S.A.

C/. Huelva, 7
E-08940 Cornellá de Llobregat
(Barcelona)
Sales:
T: +34-93-666 43 11
F: +34-93-666 43 70
sales.ba@leybold.com
Service:
T: +34-93-666 46 11
F: +34-93-685 43 70
service.ba@leybold.com

America

USA

Leybold USA Inc.

6005 Enterprise Drive
Export, PA 15632
USA
Sales and Service:
T: +1-800-764-5369
F: +1-800-325-4353
F: +1-800-215-7782
sales.ex@leybold.com
service.ex@leybold.com

Brazil

Leybold do Brasil Ltda.

Av. Tamboré, 937, Tamboré
Distrito Industrial
CEP 06460-000 Barueri - SP
Sales und Service:
T: +55 11 3376 4604
info.ju@leybold.com

Asia

P. R. China

Leybold (Tianjin)

International Trade Co. Ltd.

Beichen Economic
Development Area (BEDA),
No. 8 Western Shuangchen Road
Tianjin 300400
China
Sales and Service:
T: +86-400 038 8989
T: +86-800 818 0033
F: +86-22-2697 4061
F: +86-22-2697 2017
sales.tj@leybold.com
service.tj@leybold.com



India

Leybold India Pvt Ltd.

T-97/2, MIDC Bhosari
Pune-411 026
Indien
Sales and Service:
T: +91-80-2783 9925
F: +91-80-2783 9926
sales.bgl@leybold.com
service.bgl@leybold.com

Japan

Leybold Japan Co., Ltd.

Shin-Yokohama A.K.Bldg., 4th floor
3-23-3, Shin-Yokohama
Kohoku-ku, Yokohama-shi
Kanagawa-ken 222-0033
Japan
Sales:
T: +81-45-471-3330
F: +81-45-471-3323
sales.yh@leybold.com

Malaysia

Leybold Malaysia

Leybold Singapore Pte Ltd.

No. 1 Jalan Hi-Tech 2/6
Kulim Hi-Tech Park
Kulim, Kedah Darul
Aman 09090
Malaysia
Sales and Service:
T: +604 4020 222
F: +604 4020 221
sales.ku@leybold.com
service.ku@leybold.com

South Korea

Leybold Korea Ltd.

25, Hwangsaeul-ro 258 beon-gil,
undang-gu, Seongnam-si,
Gyeonggi-do,
(7F Sunae Finance Tower)
13595 Bundang
Sales:
T: +82-31 785 1367
F: +82-31 785 1359
sales.bd@leybold.comService:
T: +82-41 589 3035
F: +82-41 588 0166
service.cn@leybold.com

Singapore

Leybold Singapore Pte Ltd.

42 Loyang Drive
Loyang Industrial Estate
Singapore 508962
Singapore
Sales and Service:
T: +65-6303 7030
F: +65-6773 0039
info.sg@leybold.com

Taiwan

Leybold Taiwan Ltd.

10F., No. 32, Chenggong 12th St.,
Zhubei City, Hsinchu County 302
Taiwan, R.O.C.
Sales and Service:
T: +886-3-500 1688
F: +886-3-550 6523
info.hc@leybold.com



Pioneering products. Passionately applied.

Leybold GmbH

Bonner Strasse 498
D-50968 Cologne
T: +49-(0)221-347-0
F: +49-(0)221-347-1250
info@leybold.com